



narda Safety Test Solutions®

an **L3** Communications Company



Rad-IS RF Radiated Immunity System

About RF Radiated Immunity

Unlike the EMC Conducted Immunity System (refer to "PMM Cond-IS" documentation) for residential and industrial EUTs (Equipments Under Test) testing, "RF Radiated Immunity" compliance verification as for Standard IEC/EN 61000-4-3 requires a proper shielded and absorber lined testing enclosure where to inject required EM field-strength levels.

Depending on selected testing environment, which could be for example a Semi-Anechoic Chamber (SAC) or a GTEM Cell, some components to be used in the testing chain may significantly change, like Amplifiers or Antennas, while some others can remain the same at least up to 3 GHz, like Generator, Power Meter, Field Probe and Software for automatic management of both Calibration and Testing phases.

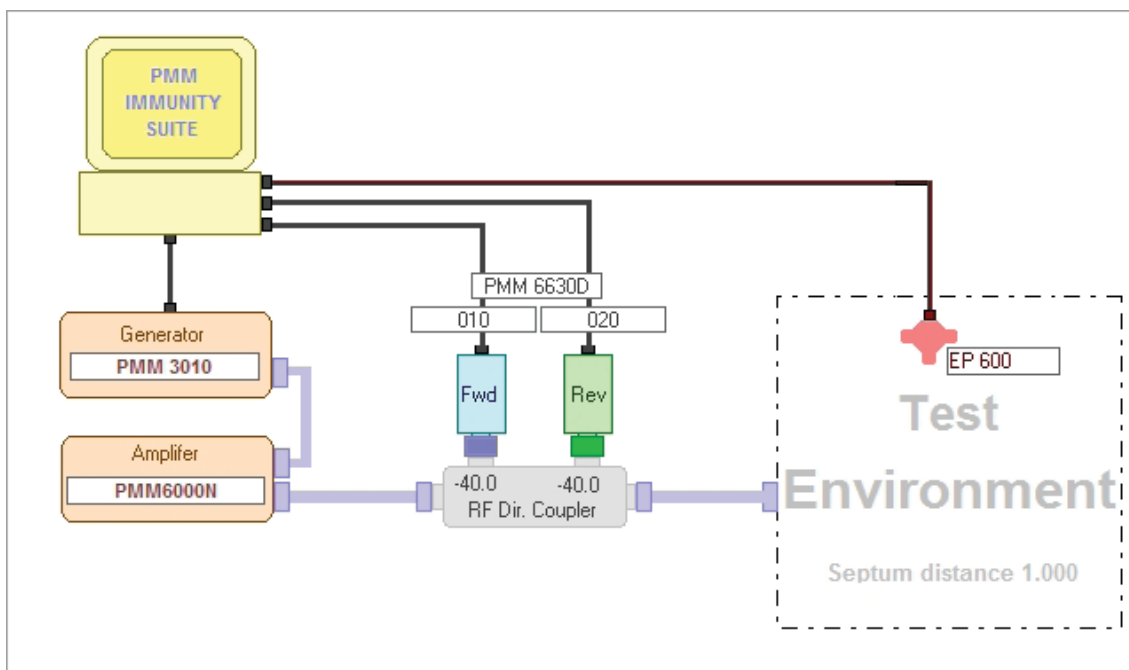



PMM Modularity

A so called "Radiated Immunity System" can still be defined for almost 80% of required components and that's exactly why NARDA STS Italy has created "Rad-IS" to fulfil core requirements of such kind of testing, leaving an open choice only for Amplifiers and Antennas/GTEMs to be driven as "slave units" while selected case by case according to the various EM field-strength levels.

Continuing with the philosophy of "Modular Approach", which still provides several advantages for actual use and future upgrades of the system when compared to "compact" solutions, main innovations are represented by the introduction of the new RF Generators 3010 / 3030, respectively reaching up to 1 and 3 GHz max frequency, True RMS Power Meter 6630 and Field Probes EP-60x Family, all easily controllable through USB Ports by any PC.

Power Meter 6630 can be operated from 9 kHz to 3 GHz, so representing an ideal companion for both Conducted and Radiated Immunity applications, while EP-60x Family are able to cover the wide frequency range of 10 kHz to 9.25 GHz and a dynamic range of 140 to 1500 V/m.

On top of this, Power Meters 6630 could also be equipped with optional Fiber Optic Adapter 6630FOA, whose optical interface provides the highest possible immunity to environmental noise (including EM field generated inside testing enclosure) without signal degradation while measuring Forward and Reverse RF Power far away from the control desk.

Thanks to such modularity, the operator can always select the best suitable components for his applications, never losing the chance to slightly modify or upgrade the system in future.

PIMS Software

The new "PMM Immunity Suite" software, accurately designed in terms of functions and user friendly approach, replaces the previous SW-03 and can manage the whole range of new PMM components during both Tests and Calibrations processes, introducing the possibility of looking at the various real time monitoring tracks from Generator, Field Probe and up to two Power Meters.

The same software suite can also manage Conducted Immunity Tests (see Cond-IS brochure) and Automotive Immunity Tests with Bulk Current Injection Probes and Striplines (see related documentation).

Rad-IS System Composition

Depending on the max field-strength required for testing in the Radiated range up to 3 GHz, PMM can offer several possible systems' choices: Rad-IS/3G-600, Rad-IS/3G-601 and Rad-IS/3G-602.

Rad-IS/3G-600 system for tests up to 140V/m includes following standard components:

- Generator 3030, 9 kHz – 3 GHz, -107 to +10 dBm
- Electric Field Probe EP-600, 100 kHz – 9.25 GHz, 0.14 to 140 V/m
- PIMS, PMM Immunity Suite software for Windows™ OS operated PCs.

Rad-IS/3G-601 system includes following standard components:

- Generator 3030, 9 kHz to 3 GHz, -107 to +10 dBm
- Electric Field Probe EP-601, 10 kHz to 9.25 GHz, 0.5 to 500 V/m
- PIMS, PMM Immunity Suite software for Windows™ OS operated PCs.

Rad-IS/3G-602 system includes following standard components:

- Generator 3030, 9 kHz to 3 GHz, -107 to +10 dBm
- Electric Field Probe EP-602, 5 kHz to 9.25 GHz, 1.5 to 1500 V/m
- PIMS, PMM Immunity Suite software for Windows™ OS operated PCs.

Note: Of course the generator 3030 can be replaced by the 3010 in case of 1 GHz max testing frequency limitation, but in such latter case components will have to be quoted separately

In addition to above mentioned components common to every Radiated Immunity System the following items will have to be selected depending on each specific testing environment's features:

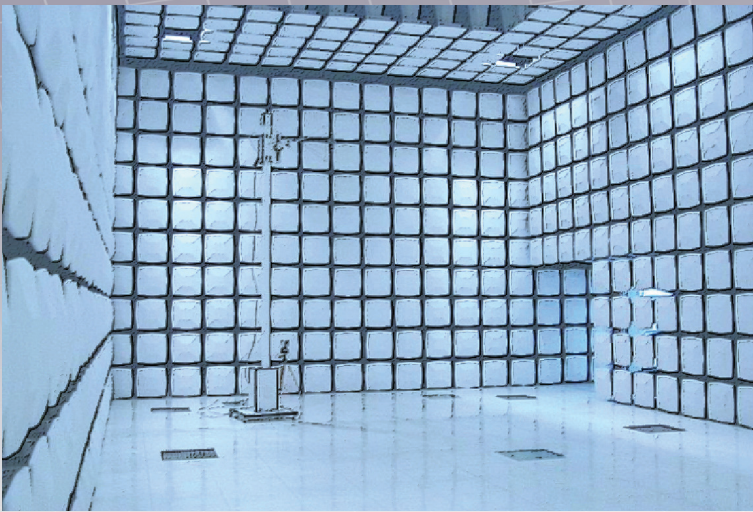

■ **SAC** (Semi-Anechoic Chamber) or **FAC** (Fully Anechoic Chamber)

- One or two RF Power Amplifiers to cover required frequency range (to be carefully chosen for best power matching with Antennas)
- One or two Antennas with optimized Antenna Factor to cover required frequency range
- N male/N male low losses RF Cables to connect Generator-Amplifiers and Amplifiers-Antennas (lengths to be defined according to installation set-up)
- Optional Directional Couplers for Fwd and Rev Power Monitoring
- Optional Power Meters 6630
- Optional Fiber Optical Adapters 6630 FOA for remote RF Power Monitoring
- Optional Automatic RF Switch between Amplifiers and Power Meters

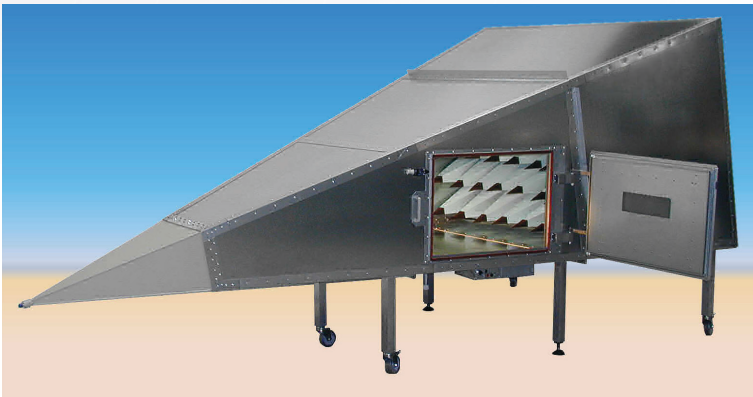

■ **GTEM Cell** (GHz Transverse Electro-Magnetic Cell)

- One or two RF Power Amplifiers to cover required frequency range (much less power than that required for SAC)
- N male/N male standard RF Cables to connect Generator-Amplifiers and Amplifiers-GTEM (lengths to be defined according to installation set-up but definitely shorter than those for SAC)
- Optional Directional Couplers for Fwd and Rev Power monitoring
- Optional Power Meters 6630
- Optional Automatic RF Switch between Amplifiers and Power Meters

Due to the very wide variety of possible solutions in terms of Antennas and Amplifiers, as well as to find out the best possible matching between these components, end-users will have to refer to local NARDA STS official distributors for custom proposals, or alternatively be in contact with main Sales Office's contact numbers mentioned on last page of this brochure.

Narda STS can also optionally provide Accredited Calibration according to ISO/IEC 17025 for RF Generators, Power Meters and Field Probes, so just ask for it at time of order in case required by internal quality assurance policy.

	Components	Rad-IS/3G-600 Radiated Immunity up to 140V/m	Rad-IS/3G-601 Radiated Immunity up to 500V/m	Rad-IS/3G-60 Radiated Immunity up to 1500V/m
RF Generator	3010	(✓)	(✓)	(✓)
	3030	✓	✓	✓
RF Power Meter	6630	optional	optional	optional
Electric Field Probe	EP-600	✓		
	EP-601		✓	
	EP-602			✓
RF Amplifiers	custom	✓	✓	✓
Antenna	custom	alternative to GTEM	alternative to GTEM	alternative to GTEM
Directional Couplers	custom	optional	optional	optional

(✓): could be selected when Max Test Frequency is limited at 1 GHz, in which case components will have to be quoted separately apart from RAD-IS/3G-60x Systems

Cross-reference between components required for each specific set-up and Rad-IS/3G-60x standard configurations.

Measuring “real” Forward & Reverse Power

The accessory 6630FOA, a Fiber Optic Adapter specifically designed for matching RF Power Meter 6630, does provide the most precise readings of Forward and Reverse Power, i.e. exactly at antenna input connector, therefore not affected by losses in cables and shielding feed through normally present between RF amplifier output and antenna.

In fact during EMC Radiated Immunity testing it's also important to check if Reverse Power reaches more than a half of Forward Power, in which case the resulting net power provided to the EUT (Equipment Under Test) cannot be considered enough to complete the test with required field strength.

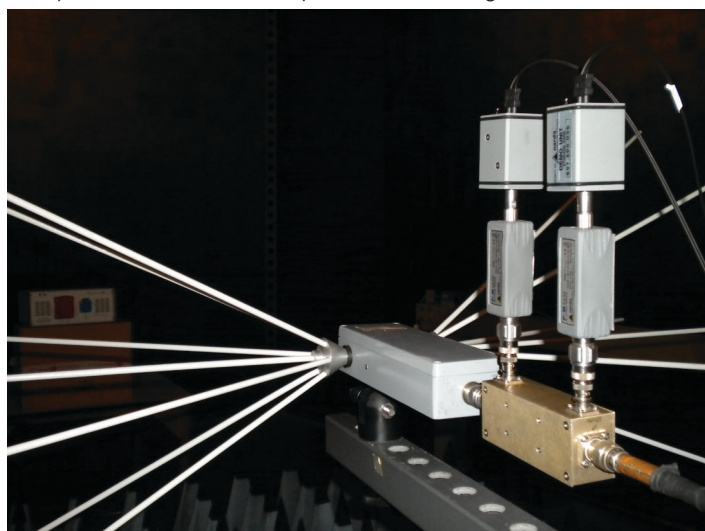

2 x 6630FOA Fiber Optic Adapters

As usually such a net power is checked from outside the testing environment, i.e. close to amplifier's output, the readings cannot take into account losses in coaxial cables passing

through the shielding and connecting the antenna inside, then measured values can be affected by a higher uncertainty. Thanks to its shielding effectiveness and optical connection, assuring immunity to RF fields up to 200V/m, 6630FOA can be



6630 FOA-Setup with Directional Coupler

assembled directly onto 6630 Power Meter and mounted on a directional coupler as closest as possible to the antenna, while a Fiber Optic to USB Adapter at opposite side assures remote control by a personal computer.

Equipping 2 x (6630FOA + 6630) on a bi-directional coupler makes it possible to measure both Forward and Reverse Power simultaneously.

Such a configuration can be completely controlled by PIMS software or through any other 3rd party software.

6630FOA is powered through rechargeable Li-Ion battery.

Up to 3 x (6630FOA + 6630) can also be driven by PIMS to match requirements of the most complex Bulk Current Injection configuration for Automotive Testing, where reading of RF power must be performed as closest as possible to BCI setup.

“PMM Immunity Suite” Software

Narda STS has developed a suite of utilities specifically designed for EMC Immunity applications, capable of driving all necessary operations for both Calibration and Testing of three main categories: Radiated, Conducted and Automotive.

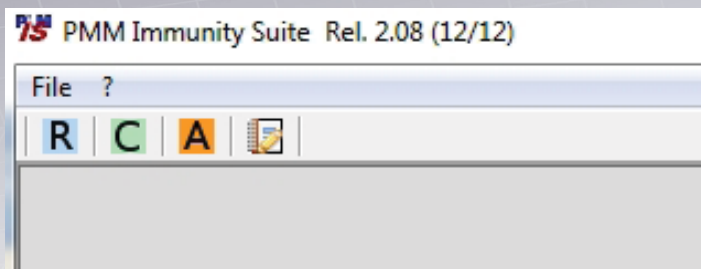

Selecting one of the letters “R”, “C” or “A” at the beginning will open the corresponding section of each category. The software is user friendly and provides a really ergonomic configuration which comfortably drives the operator through the various steps, from definition and selection of HW components to settings of required parameters and finally starting the test with “just one button”.

Program window has been designed for omni-comprehensive overview of each specific test being performed, so that operator can easily control all details with a quick glance.

A graphical scheme of the test set-up clearly reminds about proper physical connections between components, which could slightly differ between Tests and Devices' Calibration.

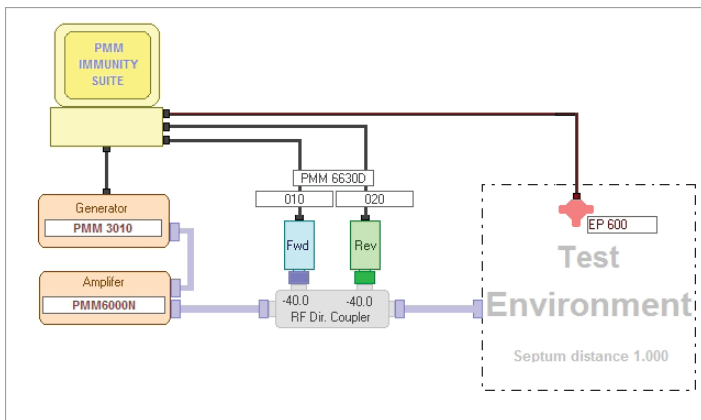

In the right portion of the screen two different tags allow simple selection of Table Creation (i.e. calibration) or Test Execution, providing all details about Generator and Power Meter status. At window's bottom some other tags provide intuitive subsequent steps for setting about various Setups, system Components and Testing parameters. On top of everything, testing and calibration procedures are always updated to state of the art requirements of reference Standards.

Radiated Immunity Tests according to IEC/EN 61000-4-3 in both Semi-Anechoic Chambers or TEM/GTEM Cells can be easily set-up and performed, including calibration of radiated field up to 16 points in a grid of Field Uniformity assurance.

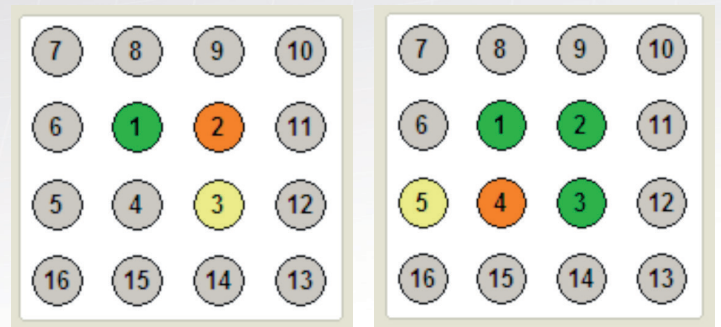

*Point 1: Completed
Point 2: Running
Point 3: Next*

*Point 1; 2, 3 Completed
Point 4: Running
Point 5: Next*

The software will automatically evaluate if calibrated field satisfies the condition of 0/+6 dB tolerance on 75% of measured points (i.e. at least 12 on the total 16 measured points).





To help operator in recognizing the rotation direction (clockwise) and position in which to move time after time the field probe, different colours are being used for "completed", "active" and "next" points, i.e. Green, Orange and Yellow respectively. Graphical traces provide real time monitoring of Generator Output and Power Meters' readings during the Test phase: A complete Report is automatically generated during the test, including information about Company, Operator, EUT and Environmental Conditions, as well as all details of settings used for the scan and Event Logs at time of failures identified by the operator.

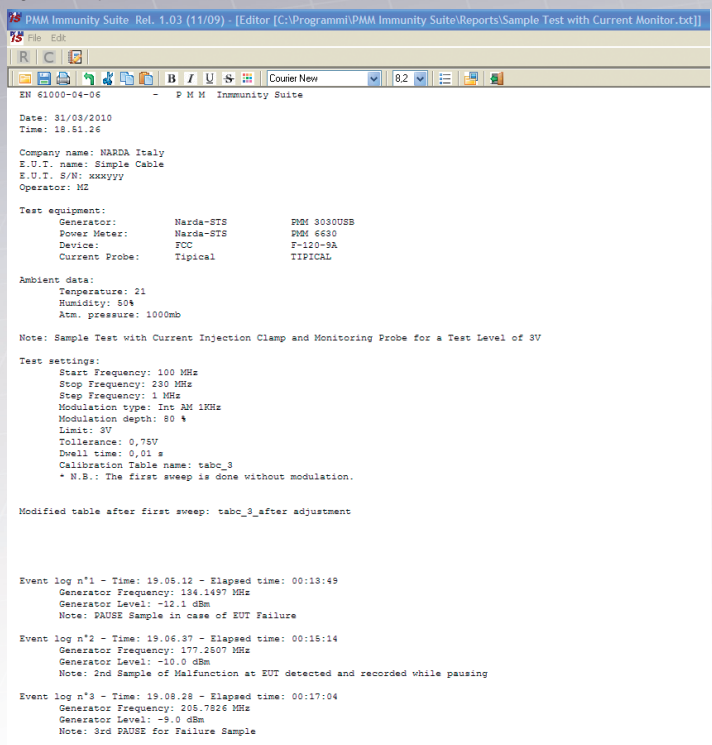

Several Auxiliary functions for debugging are also available:

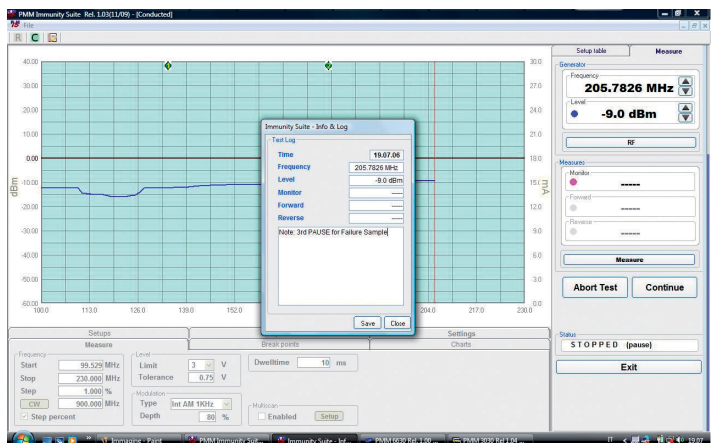

Pause during the frequency scan at EUT failures and Manual Adjustment of both Frequency and Level to identify hreshold of sesceptibility

Setups		Components	Settings
Measure		Break points	
	Freq. MHz	Comment	
Stop 1	
Stop 2	
Stop 3	
Stop 4	
Stop 5	

Break Points definition to momentarily stop the test at some frequencies for any reason

P M M MULTISCAN Setup

Multiscan Options

Start MHz	Stop MHz	Step %	Dwell mSec	Modulation	Depth %	Table Name	Level V/m
0.15	0.3	1.0	1000	Int (1 KHz)	80	tabclamp_3	3
1.2	15.5	1.0	1000	Int (1 KHz)	80	tabclamp_3	3
157.0	230.0	1.0	1000	Int (1 KHz)	80	tabclamp_3	3

Exit

Multi-Scan Table to perform test only on most critical frequency's segments and save time during debugging phase

Freq.(MHz)	Level (dBm)
0.1500	✓ -13.0
0.1515	● -12.8
0.1530	● -12.5
0.1545	● -12.3
0.1561	● -12.1
0.1577	● -11.8
0.1592	● -11.6
0.1608	● -11.4
0.1624	● -11.1
0.1641	● -10.9
0.1657	● -10.6
0.1674	● -10.4
0.1690	● -10.2
0.1707	● -9.9
0.1724	● -9.7
0.1741	● -9.5
0.1759	● -9.2
0.1776	✓ -9.0
0.1794	● -.....
0.1812	● -.....
0.1830	● -.....
0.1849	● -.....

Automatic **Fill-Up Table** by linear interpolation between arbitrary Generator Output Levels defined by the operator to generate "custom stress profiles".



EMC RF Generator 3010 and 3030

	3010	3030
Frequency range	9 kHz to 1 GHz	9 kHz to 3 GHz
Frequency resolution	1 kHz	1 kHz
Frequency accuracy (internal reference)	± 10 ppm @ f>10 MHz	± 10 ppm @ f>10 MHz
Level Range	-107 to +10 dBm	-107 to +10 dBm
Level resolution	0.1 dB	0.1 dB
Level accuracy	± 1 dB, level > -30 dBm	± 1 dB, level > -30 dBm
Output impedance	50 Ω	50 Ω
RF output connector	Type N female	Type N female
Spectral purity-harmonic	< -30dBc @ 0 dBm, f > 1 MHz	< -30dBc @ 0 dBm, f > 1 MHz
AM modulation, internal	2 Hz - 50 Hz - 400 Hz, 1 kHz; 10% to 90%	2 Hz - 50 Hz - 400 Hz, 1 kHz; 10% to 90%
AM modulation, external	2 Hz to 10 kHz; 10% to 90%	2 Hz to 10 kHz; 10% to 90%
Input impedance	600 Ω	600 Ω
Input connector	BNC female	BNC female
Internal pulse modulation	1 Hz; On/Off ratio @ 0 dBm > 40 dB 200 Hz; On/Off ratio @ 0 dBm > 40 dB 100 Hz 1:2; On/Off ratio @ 0 dBm > 40 dB 100 Hz 1:24; On/Off ratio @ 0 dBm > 40 dB 200 Hz 1:8; On/Off ratio @ 0 dBm > 40 dB 217 Hz 1:8; On/Off ratio @ 0 dBm > 40 dB 1 kHz 1:2; On/Off ratio @ 0 dBm > 40 dB	1 Hz; On/Off ratio @ 0 dBm > 40 dB 200 Hz; On/Off ratio @ 0 dBm > 40 dB 100 Hz 1:2; On/Off ratio @ 0 dBm > 40 dB 100 Hz 1:24; On/Off ratio @ 0 dBm > 40 dB 200 Hz 1:8; On/Off ratio @ 0 dBm > 40 dB 217 Hz 1:8; On/Off ratio @ 0 dBm > 40 dB 1 kHz 1:2; On/Off ratio @ 0 dBm > 40 dB
Remote control	RS232, USB 2.0 (rear), User port GPIB (external adapter)	RS232, USB 2.0 (rear), User port GPIB (external adapter)
User port	RF On/OFF, Start/Stop test	RF On/OFF, Start/Stop test
Display units	dBm, dBμV	
Operating temperature	10° to 40°C	10° to 40°C
Power Supply	10 - 15 Volt DC, 2.5A; AC/DC adapter 115/230 V 50/60 Hz	10 - 15 Volt DC, 2.5A; Li-Ion interchangeable battery (4 h operations, average); AC universal adapter/charger
Plug-in battery pack (model 3030-02)	-	Li-Ion, rechargeable 3 hours average operation time
Dimensions	235 x 105 x 335 mm (WxHxD)	235 x 105 x 335 mm (WxHxD)
Weight	3.5 kg	3.5 kg (mod. 3030-01) 4.3 kg (mod. 3030-02)



USB RF Power Sensor 6630

Frequency range	9 kHz to 3 GHz
Power measurement range	100 nW to 1 W -40 to + 30 dBm
Max input power	2 W peak envelope max. 300 ms
Power linearity	-40 dBm to 30 dBm at 50 MHz: 0,2 dB
Measurement accuracy ^{1, 2, 3}	< 0.35 dB
Measurement ranges (Automatic change)	High: +30 to -9 dBm Low: -9 to -40 dBm 1 dB typical switching point hysteresis
Max SWR	10 kHz to 300 kHz 1.10 from +30 dBm to -9 dBm >300 kHz to 100 MHz 1.05 >100 MHz to 1 GHz 1.10 > 1 GHz to 3 GHz 1.25
	10 kHz to 3GHz 1.20 from < -9 dBm to -40 dBm
Operating temperature	-10°C ÷ +50°C
Power supply	5 VDC - 100 mA from USB port
RF connector	N male, 50 Ω
PC communication interface	USB 1.0 - 1.1 - 2.0
PC software	WIN6630 utility (supplied)
PC software settings	N° of Averages (1 to 1024) Offset Correction factor
Measuring units	dBm, dBμV, W, Vrms
Dimensions	30 x 30 x 95 mm (WxHxD)
Weight	0.12 kg

1. Max. SWR of source: 1.25

2. Calculated with worst calibration uncertainties to the calibration factor of 0.17 dB

3. At set frequency



Common Specifications Prome EP-60x

Resolution	0,01 V/m
Sensors	Six monopoles
Measurement mode	X-Y-Z axis simultaneous sampling
Sampling rate	22 to 0,03 Samples/s depending on filter settings
Digital filtering	Low-pass 2,3 to 28 Hz; 80 dB notch 50/60 Hz
Internal battery	3V - 5 mA/h, Li-Mn rechargeable
Operation time	80 hours @ 0,4 S/s, 28 Hz filter 60 hours @ 5 S/s, 28Hz filter
Recharging time	48 hours for full operation time 8 hrs rech. = 12 hrs operation @ 5 S/s 1 hr rech. = 5 hrs operation @ 0,4 S/s
Internal data memory	Serial nr. - Calibration factors & date Firmware version
Communication	Bidirectional fiber optic link
Fiber optic connector	HFBR-0500
Fiber optic length	10 m, standard 20/40 m options
Fiber optic to PC	Fiber optic to RS232 converter RS232 to USB converter
PC software	Displays field, temperature, battery Sampling, filters, averaging, frequency setting Manual data logging as text file
Operating temperature	-10 °C + 50 °C
Temperature reading resolution	0,1 °C
Battery voltage reading resolution	10 mV

Main Specifications

	EP-600	EP-601	EP-602	EP-603	EP-604
Frequency Range	100 kHz to 9,25 GHz	10 kHz to 9,25 GHz	5 kHz to 9,25 GHz	300 kHz to 18 GHz	300 kHz to 26.5 GHz
Flatness	Frequency correction OFF 1 to 150 MHz: 0,8 dB 0,5 to 6000 MHz: 1,6 dB 0,3 to 7500 MHz: 3,2 dB Frequency correction ON, typ. 0,3 to 7500 MHz: 0,4 dB	Frequency correction OFF 0,1 to 150 MHz: 0,4 dB 0,05 to 6000 MHz: 1,6 dB 0,03 to 7500 MHz: 3,2 dB Frequency correction ON, typ. 0,05 to 7500 MHz: 0,4 dB	Frequency correction OFF 0,1 to 150 MHz: 0,4 dB 0,05 to 6000 MHz: 1,6 dB 0,03 to 7500 MHz: 3,2 dB Frequency correction ON, typ. 0,05 to 7500 MHz: 0,4 dB	Frequency correction OFF 3 to 8200 MHz: 1,4 dB 1 to 12000 MHz: 2,4 dB 0,6 to 18000 MHz: 3,8 dB Frequency correction ON, typ. 0,3 to 18000 MHz: 0,4 dB	Frequency correction OFF 10 to 18000 MHz: 1,8 dB 3 to 23000 MHz: 3,2 dB Frequency correction ON, typ. 0,3 to 26500 MHz: 0,4 dB
Dynamic Range	0,14 to 140 V/m 60 dB single range	0,5 to 500 V/m 60 dB single range	1,5 to 1500 V/m 60 dB single range	0,17 to 170 V/m 60 dB single range	0,4 to 800 V/m 66 dB single range
Overload	300 V/m	1000 V/m	3000 V/m	350 V/m	1600 V/m
Dimensions (overall)	53mm	53mm	53mm	53mm	45mm
Weight (incl. 1 m fiber optic pigtail)	23 g.	23 g.	23 g.	23 g.	22 g.



Fiber Optic Adapter 6630FOA

Output	fiber Optic Connector (standard 20 m Provided) Maximum lenght of fiber optic: 80 meters
Input	Connector 4 poles
Compatibility	With RF power sensor 6630
Power Supply	Internal battery 3.7 V - 1.8 Ah Li-Ion, rechargeable through AC/DC Adapter
Operating Time	8 hours
Recharging Time	4 hours
PC link	FO/USB Adapter
RF Immunity	up to 200 V/m
Temperature Oprating ange	-10°C to 50°C
Dimensions	40 x 40 x 65 mm (WxHxD)
Weight	168 g

Ideal for BCI Automotive Testing

Ordering Information Radiated Immunity System for IEC/EN 61000-4-3

Rad-IS/3G-600 (up to 3 GHz - 140 V/m)	Conducted Immunity System composed by: 3030-01 + EP-600 + PMM Immunity Suite software
Rad-IS/3G-601 (up to 3 GHz - 500 V/m)	Conducted Immunity System composed by: 3030-01 + EP-601 + PMM Immunity Suite software
Rad-IS/3G-602 (up to 3 GHz - 1500 V/m)	Conducted Immunity System composed by: 3030-01 + EP-602 + PMM Immunity Suite software

Components available separately

EP-600	Field probe 100 kHz to 9.25 GHz, 0.14 to 140 V/m
EP-601	Field probe 10 kHz to 9.25 GHz, 0.5 to 500 V/m
EP-602	Field probe 100 kHz to 9.25 GHz, 1.5 to 1500 V/m
EP-603	Field probe 300 kHz to 18GHz, 0.17 to 170 V/m
3010	Signal generator 9 kHz to 1 GHz, AC power
3030-01	Signal generator 9 kHz to 3 GHz, AC power
3030-02	Signal generator 9 kHz to 3 GHz, AC power, Li-Ion internal rechargeable battery
6000N	10/15W RF Linear Amplifier 9 kHz - 230 MHz
6630	USB RF Power sensor 9 kHz - 3 GHz
6630 FOA	Adapter for RF Power meter; fiber optic to USB connection (10 m). Internal rechargeable battery.
SB-10	Programmable switching box with 10 inputs; software included
PIMS	PMM Immunity Software for IEC/EN 6100-4-6 / 6100-4-3 (Available for free on our website)

Additional RF Probes with separate Electro-Optic converter

EP-745	Isotropic E-Field Sensor 100 kHz to 7 GHz, 0.35 to 450 V/m. Requires OR-03 optical repeater
EP-330	Isotropic E-Field Sensor 100 kHz to 3 GHz, 0.3 to 300 V/m. Requires OR-03 optical repeater
EP-183	Isotropic E-Field Sensor 1 MHz to 18 GHz, 0.8 to 800 V/m. Requires OR-03 optical repeater
EP-408	Isotropic E-Field Sensor 1 MHz to 40 GHz, 0.8 to 800 V/m. Requires OR-03 optical repeater
EP-105	Isotropic E-Field Sensor 100 kHz to 1 GHz, 0.05 to 50 V/m. Requires OR-03 optical repeater
EP-301	Isotropic E-Field Sensor 100 kHz to 3 GHz, 1 to 1000 V/m. Requires OR-03 optical repeater
HP-102	Isotropic H-Field Sensor 30 MHz to 1 GHz, 20 mA/m to 20 A/m. Requires OR-03 optical repeater
HP-032	Isotropic H-Field Sensor 100 kHz to 30 MHz, 20 mA/m to 20 A/m. Requires OR-03 optical repeater
OR-03	Programmable Optical Repeater

Spares and Accessories

520.000.158	EP-60x charger fixture
650.000.030	EP-60x AC/DC adapter, 100-240 V, 50/60 Hz, 12 V 1.5 A
FO-EP600/20	EP-60x fiber optic, 20 m length
FO-EP600/40	EP-60x fiber optic, 40 m length
8053-OC	EP-60x optical to RS-232 adapter
9010/RMA	3010 & 3030 19" rack mount adapter
BP01	3030-02 Li-Ion battery pack
9010/AC	3010 & 3030 AC/DC adapter
FO-8053/20	OR-03 fiber optic 20 m length
FO-8053/40	OR-03 fiber optic 40 m length

Sales Office:
Via Leonardo da Vinci, 21/23
20090 Segrate (Milano) - ITALY
Phone: +39 02 2699871
Fax: +39 02 26998700



E-Mail: nardait.support@L-3com.com
Internet: www.narda-sts.it

Headquarter:
Via Benessea, 29/B
17035 Cisano sul Neva (SV) - ITALY
Phone: +39 0182 58641
Fax: +39 0182 586400